

# METTLER TOLEDO

## DIVA Service Manual

### PSC 8200 Magellan Scanner





## **INTRODUCTION**

This publication is provided solely as a guide for individuals who have purchased the METTLER TOLEDO Diva scale product.

Information regarding METTLER TOLEDO Technical Training may be obtained by writing to:

**METTLER TOLEDO**  
1900 Polaris Parkway  
Columbus, Ohio 43240-2020  
(614) 438-4511

©Mettler-Toledo, LLC 2012

No part of this manual may be reproduced or transmitted in any form or by any means, electronic or mechanical, including photocopying and recording, for any purpose without the express written permission of Mettler-Toledo, LLC.



U.S. Government Restricted Rights: This documentation is furnished with Restricted Rights.



**METTLER TOLEDO RESERVES THE RIGHT TO MAKE REFINEMENTS  
OR CHANGES WITHOUT NOTICE.**

# Precautions

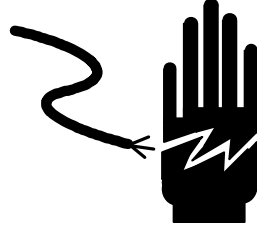
---

	 <b>WARNING</b>
	ONLY PERMIT QUALIFIED PERSONNEL TO SERVICE THIS EQUIPMENT. EXERCISE CARE WHEN MAKING CHECKS, TESTS AND ADJUSTMENTS THAT MUST BE MADE WITH POWER ON. FAILING TO OBSERVE THESE PRECAUTIONS CAN RESULT IN BODILY HARM.

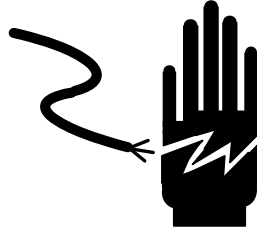
	 <b>WARNING</b>
	FOR CONTINUED PROTECTION AGAINST SHOCK HAZARD CONNECT TO PROPERLY GROUNDED OUTLET ONLY. DO NOT REMOVE THE GROUND PRONG.

	 <b>WARNING</b>
	DISCONNECT ALL POWER TO THIS UNIT BEFORE REMOVING THE FUSE OR SERVICING. FAILURE TO DO SO MAY RESULT IN BODILY INJURY OR PROPERTY DAMAGE.

 <b>CAUTION</b>
BEFORE CONNECTING/DISCONNECTING ANY INTERNAL ELECTRONIC COMPONENTS OR INTERCONNECTING WIRING BETWEEN ELECTRONIC EQUIPMENT ALWAYS REMOVE POWER AND WAIT AT LEAST THIRTY (30) SECONDS BEFORE ANY CONNECTIONS OR DIS-CONNECTIONS ARE MADE. FAILURE TO OBSERVE THESE PRECAUTIONS COULD RESULT IN DAMAGE TO OR DESTRUCTION OF THE EQUIPMENT OR BODILY HARM.

 <b>CAUTION</b>
OBSERVE PRECAUTIONS FOR HANDLING ELECTROSTATIC SENSITIVE DEVICES.

---

# Contents

---

<b>1</b>	<b>INTRODUCTION .....</b>	<b>1</b>
1.1	RELIABILITY .....	1
1.2	STANDARD FEATURES .....	1
1.3	PHYSICAL DIMENSIONS .....	2
1.4	POWER REQUIREMENTS .....	3
1.5	TEMPERATURE AND HUMIDITY .....	3
1.6	WEIGHTS AND MEASURES APPROVAL .....	3
1.7	OPTION .....	3
<b>2</b>	<b>INSTALLATION .....</b>	<b>6</b>
2.1	PRECAUTIONS .....	6
2.2	CONTENTS OF PACKAGING .....	6
2.3	SETUP.....	6
2.4	POWER UP SEQUENCE .....	7
2.5	SEALING.....	8
<b>3</b>	<b>SET-UP AND CALIBRATION .....</b>	<b>10</b>
3.1	SERVICE SETUP MODE:.....	10
3.2	MASTER SETUP MODE:.....	11
3.3	SET UP SOFT SWITCH AND DEFAULT TABLE.....	12
3.4	COUNTRY DEFAULTS .....	14
3.5	GEOCAL <sup>®</sup> COUNTRY CODES.....	15
3.6	GEOCAL <sup>®</sup> USA STATE LOCATION CODES .....	16
3.7	CALIBRATION .....	18
<b>4</b>	<b>OPERATING INSTRUCTIONS .....</b>	<b>20</b>
4.1	DISPLAYS .....	20
4.2	KEYBOARD .....	21
4.3	CURSORS.....	21
4.4	OPERATIONS.....	22
4.4.1	<i>Weighing and Communication</i> .....	22
4.4.2	<i>Backlight function</i> .....	22
4.4.3	<i>Re-zero Functions</i> .....	22
4.4.4	<i>Tare Function</i> .....	22
<b>5</b>	<b>SERVICE AND MAINTENANCE.....</b>	<b>23</b>
5.1	CLEANING AND REGULAR MAINTENANCE .....	23
5.2	TROUBLESHOOTING .....	23
5.3	CONNECTIONS TO A POS .....	24
5.3.1	<i>Communications Pinout</i> .....	24
5.3.2	<i>Handshaking</i> .....	24
5.4	PARTS AND DESCRIPTIONS.....	25
5.5	REPLACEMENT PARTS ORDER NUMBERS.....	27
<b>6</b>	<b>APPENDIX.....</b>	<b>29</b>
6.1	PROTOCOLS.....	29
6.1.1	<i>NCI – ECR</i> .....	30
6.1.3	<i>8217 Mettler Toledo</i> .....	35
6.1.4	<i>8213 Mettler Toledo</i> .....	40
6.1.5	<i>EPOS 1</i> .....	44
6.1.6	<i>EPOS 2</i> .....	46
6.1.8	<i>Dialog 06</i> .....	49
6.1.9	<i>Dialog 04 / 02</i> .....	54
6.1.11	<i>ICL</i> .....	58



# 1 Introduction

The DIVA is designed to mount on the Metrologic Stratos Bi-Optic Scanners and communicate with ECR and POS systems for weighing needs.

## 1.1 Reliability

The DIVA is developed, produced, and tested in a Mettler Toledo facility that has been audited and registered according to international ISO 9001 quality standards and ISO 14000 environment control program.

## 1.2 Standard Features

- Capacity: 6x0.002kg; 15 x 0.005kg – both single and dual ranges  
15x0.005lb; 30x0.01lb – both single and dual ranges
- Platter: Stainless Steel: 260 x 280mm
- Tower Display: LCD with backlight, Single Line for Weight Only applications and a Four Line for Price Computing applications
- LCD: 13.5mm high character weight (5 digits); unit price (6 digits); total price (6 digits).
- Keyboard: two keys, with tactile and tone feedback when pressing the key.
- Power supply: Power provided via connection with the scanner.
- A sealable Setup and Calibration Software switch
- Basic functions: Zero; Tare
- RS-232 interface

### 1.3 Physical Dimensions

The dimensions of the scale with tower is as follows:



**Price Computing Display**



**Weight Only Display**



## 1.4 Power Requirements

Power is supplied via a Y-cable connected to the Scanner power supply.

## 1.5 Temperature and Humidity

Working temperature range: -10 to +40 °C (+14 to +114F) at 10 to 85% humidity, non-condensing.

Storage temperature range: from -25 to +50°C at 10 to 85% humidity, non-condensing.

## 1.6 Weights and Measures Approval

- EC Type-approval Certificate: T6941
- EC Test Certificate: TC6942 (when the scale is used without the Mettler-Toledo displays)
- NTEP: Certificate of Conformance Number 06-024

## 1.7 Option

- Remote display bracket
- Dual Display

**Mettler-Toledo (ChangZhou) Scale & System Ltd.**

Legal Metrology

Declaration of Conformity  
 Konformitätserklärung  
 Déclaration de conformité  
 Declaración de Conformidad  
 Conformiteitsverklaring  
 Dichiarazione di conformità

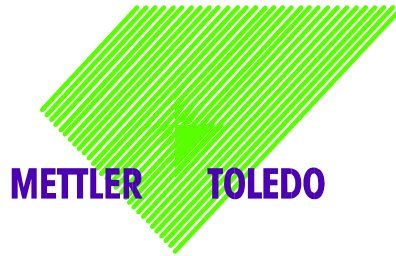

We/Wir/Nous/Nosotros/Noi

**Mettler-Toledo (ChangZhou) Scale & System Ltd.**  
 111 ChangXi Road, ChangZhou, JiangSu, 213001, P.R.China

**declare under our sole responsibility that the product,**  
 erklären, in alleiniger Verantwortung, dass dieses Produkt,  
 déclarons sous notre seule responsabilité que le produit,  
 declaramos, bajo nuestra sola responsabilidad, que el producto,  
 verklaren onder onze verantwoordelijkheid, dat het product,  
 dichiariamo sotto nostra unica responsabilità, che il prodotto,

**Model/Type: DIVA**

**To which this declaration relates , is in conformity with the following standard(s) or other normative document(s),**  
 auf das sich diese Erklärung bezieht , mit der/den folgenden Norm(en) oder Richtlinie(n) übereinstimmt.  
 Auquel se réfère cette déclaration est conforme à la (aux) norme(s) ou au(x) document(s) normatif(s).  
 Al que se refiere esta declaración es conforme a la(s) norma(s) u otro(s) documento(s) normativo(s).  
 Waarnaar deze verklaring verwijst, aan de volende norm(en) of richtlijn(en) beantwoordt.  
 A cui si riferisce questa dichiarazione è conforme alla/e sequente/i norma/e o documento/i normativo/i.

EC Marking	EC Directive:	Applicable Standards:
	73/23/EEC Low Voltage Directive	EN60950
	89/336/EEC EMC Directive	EN61326:1997+A1+A2 (Class B) EN61000-3-2 EN61000-3-3
<i>For non-automatic weighing instrument used in an Article 1,2.(a) application ,additional metrological marking according to Annex IV of Council Directive 90/384/EEC must be attached to the instrument</i>		
year  0103	90/384/EEC Non-automatic Weighing Instruments Directive	EN45501 1)

- 1) valid only for "DIVA" base in connection with approved terminal.  
 zulässig nur für "DIVA" Waage zusammen mit zugelassenem Terminal  
 valid only for la base "DIVA" dans connection with approved le terminal  
 válido solamente para la base "DIVA" en la conexión con el terminal aprobado.  
 valido soltanto per la base "DIVA" in relazione al terminale approvato.

ChangZhou, April 2006  
 Mettler-Toledo (ChangZhou) Scale & System Ltd.

Yanq JiaWu, Quality Assurance

Important notice concerning verified instruments see overleaf!

### Important notice for verified weighing instruments

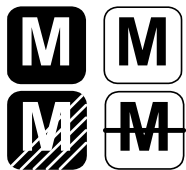

Weighing Instruments verified at the place of manufacture bear the preceding mark on the packing label and a green "M" sticker on the descriptive plate. They may be set to work immediately.

Weighing Instruments which are verified in two steps have no green "M" on the descriptive plate and bear the preceding identification mark on the packing label. The second step of the verification must be carried out by the approved Mettler-Toledo service or by the W&M authorities. Please contact your Mettler-Toledo organization.

The first step of the verification has been carried out at the manufacturing plant. It comprises all tests according to EN 45501-8.2.2. If national regulations in individual countries limit the period of validity of the certification, the operator of such a scale is himself responsible for its timely re-certification.

### Wichtiger Vermerk für geeichte Wägeinstrumente in EU-Ländern

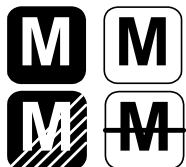

Werksgereichte Waagen tragen vorstehendes Kennzeichen auf dem Packetkett und einen grünen "M"-Kleber auf dem Eichschild. Sie dürfen sofort in Betrieb genommen werden.

Waagen, die in zwei Schritten geeicht werden und kein grünes "M" auf dem Eichschild haben, tragen vorstehendes Kennzeichen auf dem Packetkett. Der zweite Schritt der Eichung ist durch den behördlich anerkannten Mettler-Toledo Kundendienst oder durch den Eichbeamten durchzuführen. Bitte nehmen Sie mit dem Mettler-Toledo Kundendienst Kontakt auf.

Der erste Schritt der Eichung wurde im Herstellerwerk durchgeführt. Er umfasst alle Prüfungen gemäß EN45501-8.2.2. Sofern gemäß den nationalen Vorschriften in den einzelnen Staaten die Gültigkeitsdauer der Eichung beschränkt ist, ist der Betreiber einer solchen Waage für die rechtzeitige Nacheichung selbst verantwortlich.

### Remarque importante pour les Instruments de pesages vérifiés dans les pays membre de l'Union Européenne



Les instruments de pesage vérifiés en usine portent l'identification ci-contre sur leur emballage et un autocollant "M" vert sur la plaque d'identification. Ils peuvent être utilisés après leur installation.

Les instruments de pesage vérifiés en deux étapes portent l'identification ci-contre sur leur emballage et n'ont pas d'autocollant "M" vert sur la plaque d'identification. La seconde étape de la vérification doit être effectuée par le service technique Mettler-Toledo autorisé responsable. Veuillez s.v.p. contacter le service technique Mettler-Toledo.

La première étape de la vérification a été effectuée en usine. Cela comprend tous les essais suivant la norme EN45501-8.2.2. Dans la mesure où la durée de la vérification est limitée en fonction des prescriptions nationales dans les différents pays, l'utilisateur d'une telle balance est lui-même responsable de la vérification ultérieure dans les délais.

### Nota importante para básculas verificadas en países de la UE



Las balanzas verificadas en origen llevan esta indicación en la etiqueta del embalaje y con la etiqueta "M" sobre fondo verde en la placa de características pueden ser utilizadas inmediatamente.

Balanzas cuya verificación se realiza en dos fases llevan esta indicación en la etiqueta del embalaje (ninguna etiqueta "M" verde en la placa de características). La segunda fase de la verificación debe ser realizada por personal Mettler-Toledo acreditado, o por la autoridad competente. Rogamos contacten con el Servicio Técnico de Mettler-Toledo.

La primera fase de la verificación ha sido realizada en origen. Incluye todos los ensayos según lo norma EN45501-8.2.2. Si el plazo de validez de la verificación está limitado por las normas nacionales de cada estado, el usuario será responsable de las verificaciones posteriores reglamentarias de su balanza.

### Nota importante per la balance approvate nei paesi UE

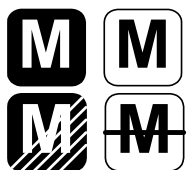

Le balance verificate in fabbrica portano questo contrassegno sull'etichetta dell'imballo e con il sigillo "M" su stando verde sulla targhetta metrological possono essere messe in uso immediatamente.

Le balance che vengono verificate in due fasi, portano questo contrassegno sull'etichetta dell'imballo e non portano il sigillo "M" sulla targhetta metrological. La seconda fase della verifica dev'essere eseguita dal servizio assistenza Mettler-Toledo autorizzato, oppure dalla autorità competente. Prego contattare il vostro servizio assistenza Mettler-Toledo.

La prima fase della verifica è stata eseguita dal produttore e comprende tutte le prove previste dalla norma EN 45501-8.2.2. Se la durata di validità della verifica è limitata in accordo con le prescrizioni nazionali vigenti nei singoli paesi, l'utilizzatore stesso di una bilancia di tale tipo sarà responsabile dell'esecuzione, entro le date di scadenza previste, delle verifiche periodiche.

## 2 Installation

### 2.1 Precautions

Before you install your DIVA scale, keep in mind the following factors, which might have a negative influence on the scale's operation:

- Vibration diminishes the scale's ability to measure accurately. Excessive vibration from equipment such as conveyors can cause inaccurate and non-repeatable readings.
- Be sure the scale is leveled properly.
- Air currents can also diminish a scales performance. Avoid placing the scale in front of or directly under air vents.
- Other than items being weighed, keep the scale free from objects rubbing or pressing against the platter.

### 2.2 Contents of Packaging

Package contents for all DIVA units include:

- DIVA scale base
- Operation manual
- Display Cable
- Tower included and attachment hardware (The optional display may be packed separately)
- Sealing Kit

### 2.3 Setup

1. Open the box, carefully remove the packing material, take all items out of the carton.
2. Attach the display as described below, depending on which version of scale you ordered:

#### For Price Computing Version:

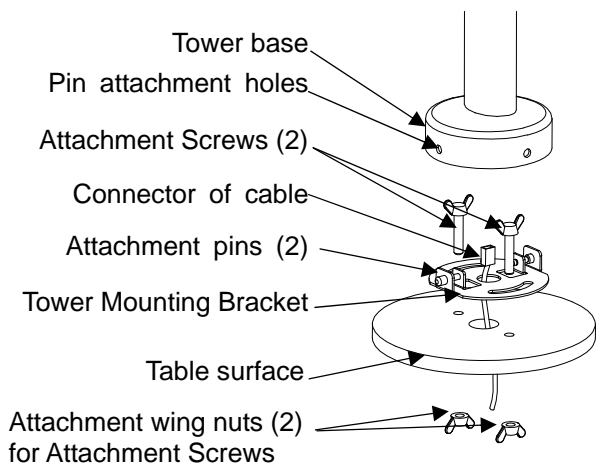

- A: Pull the connector of the cable through the holes of the table surface and tower mounting bracket;
- B: Put (2) screws through the (2) arch holes on the bracket and (2) holes on the table surface;
- C: Attach cover to the surface of table with (2) nuts.
- D: Connect the cable to the connector at the bottom of the tower display
- E: Attach the base of the display to the mounting bracket by insuring that the (2) pins on the bracket are inserted in the holes of the base to attach the tower and snap the tower into place.

**For Weigh Only Version:**

The Weigh Only version comes with a tower mount.

Assemble the Weigh Only tower as is illustrated here:

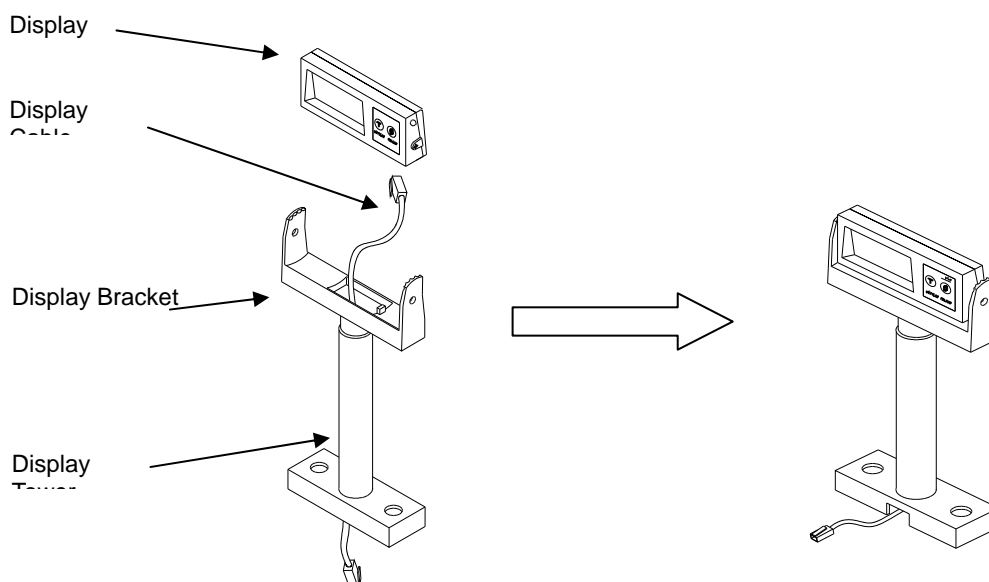

- Level the scale by turning the adjustable feet on the bottom of the unit. Adjust the feet until the level bubble is in the center of the circle.

Bubble indicator:

Correct



Wrong



- Put the platter on top of the DIVA scale.
- Connect the tower display cable to the appropriate port on the scanner.
- Connect the power cord from the wall transformer to the scanner.

## 2.4 Power up sequence

**Note: Before powering on the DIVA scale, always make sure there is nothing on the platter.**

Apply power to the scanner. The scale will go through a series of self-tests and then will proceed to normal operating mode. The power-up sequence is as follows:

- All segments of the display characters are lit. This verifies operation of all segments;
- The scale displays the country code and GEO code, software part number and revision.
- The scale then captures zero and is ready for normal operation.

## 2.5 Sealing

After installation is complete, legal-for-trade applications require sealing the enclosure so the settings cannot be changed.

### The label sealing sequence

Security Sticker 28x19mm, material Vinyl white 3690 E UL, text color black.

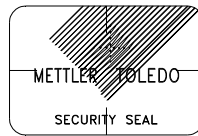

There are 3 labels that used for sealing. The position for the sealing labels is shown below.

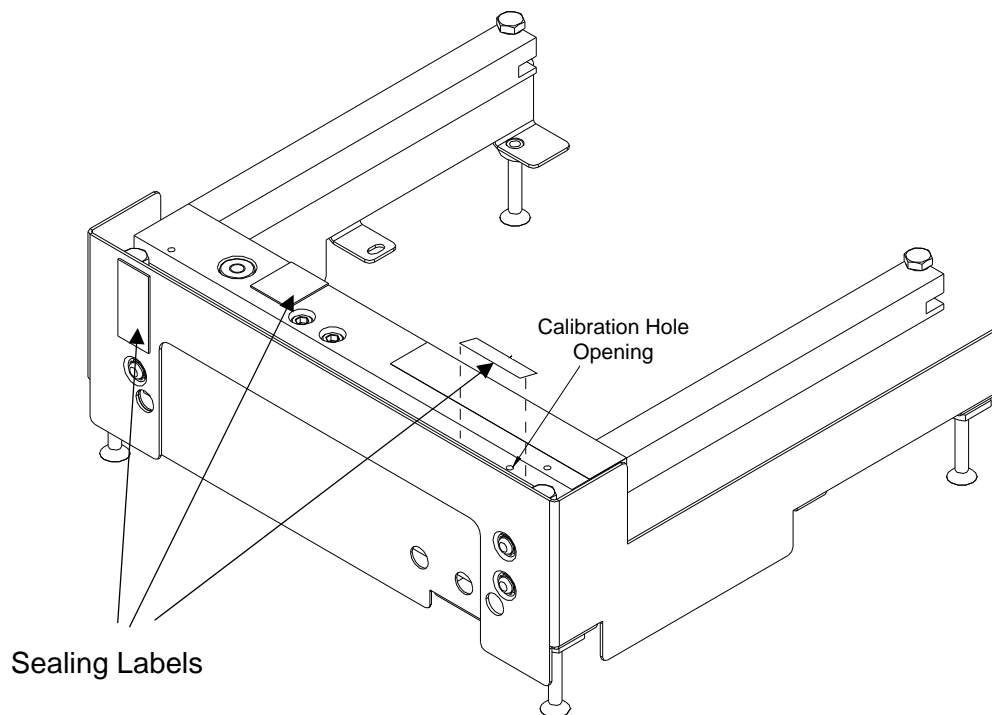



For your notes:

### 3 Set-up and Calibration

There are two types of setup modes. The first is called “Service Mode” and it allows full access to all soft switches and to calibrate the scale. The second is called “Master Mode” and it only allows access to soft switches that do not affect the metrology of the scale.

#### 3.1 Service setup mode:

In order to access the Service Mode, break the seal and insert a thin rod like small screwdriver through the calibration hole and press the button as illustrated:

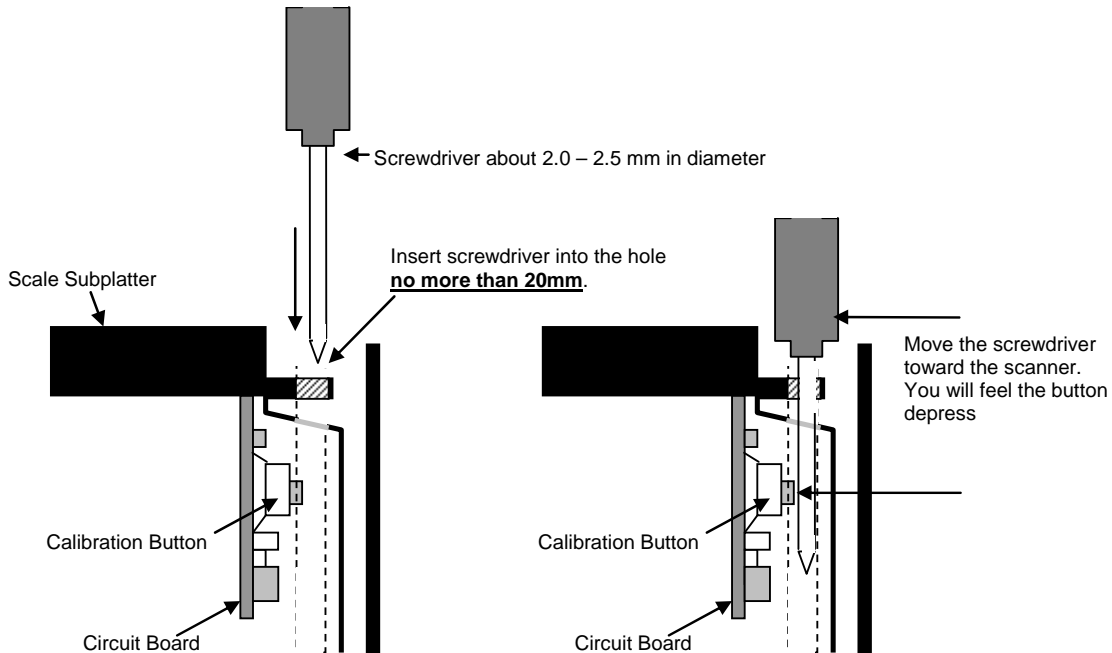

To change settings using the Diva display follow the directions below.

During the set up procedure, the display will start off by showing the following. This is a configuration mode for the scanner.

#### Price Computing Version



#### Weigh Only Version





Press the Zero Key:

### Price Computing Version



### Weigh Only Version

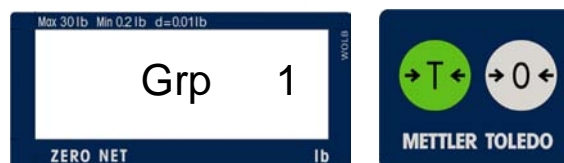

You can press the Tare key to move to Grp 2, 3, or 4. To go into a particular Group, press the Zero Key. Below is what you will see when going into the first Step of Group 1.

### Price Computing Version



### Weigh Only Version



Refer to **Section 3.3 Setup and Soft Switch Default Table** for all available settings.

## 3.2 Master setup mode:

This mode allows an operator to change certain softswitches not protected behind the seal directly from the keyboard or through the scanner. To get into Master mode, press and hold >T< key for eight seconds until "Grp 1" is displayed. Refer to the **Section 3.3 Set Up Softswitch and Default Table** for the accessibility of softswitches via keyboard.

The scale can be configured for your specific needs through a special interactive set up procedure. In order to access the various prompts, you must utilize the following keys during the scale setup mode.



This key is used to accept a choice and then advance one softswitch at a time.



This key is used to step through the options.

### 3.3 Set up Soft Switch and Default Table

Group.Step	Function	Possible Selections	Master Mode Access
<b>Group 1</b>		<b>Press Zero to Enter</b> <b>Press Tare to go to Group 2</b>	
1.1	Country Select	DE (Germany) FR (France) US (USA) CA (Canada) AT (Austria and Croatia and Slovenia) ES (Portugal and Spain) BE (Belgium, Netherland, Poland and England) IT (Italy) CH (Kazachstan and Switzerland) UA (Ukraine) RU (Russia) HU (Hungary) SK (Slovakia) CZ (Czechia) EJPORT (General export) CN (China)	No
1.2	Initialize to Defaults	YES – Soft switches will be reset to factory defaults NO – Soft switches will remain in current configuration	No
1.3	Beeper	ON – Scale will “beep” when a key is pressed. OFF – No sound is made when a key is pressed.	Yes
1.4	Zero cursor	ON – Display zero cursor. OFF – Disable zero cursor.	Yes
1.5	Decimal point	ON - . OFF - ,	Yes
1.6*	Decimal Position	0 - 4 – Digits right of the decimal for Unit and Total Price fields.	No
1.7	Auto-clear of Tare	ON – Tare is automatically cleared when weight is removed. OFF – Tare is not cleared when weight is removed.	No
1.8	Weight unit	1 – lbs range (0 to 30 lbs) 2 – kg range (0 to 15kg) 3 – kg multi-interval (0 to 6kg, 6 to 15kg) 4 – lbs multi-interval (0 to 15lb, 15 to 30 lb)	No
1.9	Expanded Weight Display	ON – Division quantity is displayed, Maximum is 30000. OFF – Weight is displayed in normal display increments.	No
1.10	Enable Main PCB Service Mode Button	ON – Button on Main PCB Enabled OFF – Button on Main PCB Disabled	No
<b>Group 2</b>		<b>Press Zero to Enter</b> <b>Press Tare to go to Group 3</b>	
2.1	Tare Enable	ON – Enables tare function. OFF – Disables tare function.	No
2.2	Chain Tare Enable	ON – Enables multiple tares. OFF – Only one tare per transaction is allowed.	No
2.3*	Total Price Round (To Nearest 0 or 5)	ON – The total price will round up or down to 0 or 5. OFF – Total price will not be rounded.	No
2.4	Digital Filter Selection	0 - 3 – Minimal to High	Yes
2.5	GEO	0 through 31 – See GeoCal chart below	No
2.6	Calibration	No – Do not enter calibration mode Yes – Calibrate scale	No
2.7	Display (1 or 4 Line)	0 – None 1 – 1 Line 2 – 4 Line	Yes
2.8	Display Update Rate	0-100 – Adjust display rate	Yes
2.9	Enter Flash Mode	ON – Enter Flash Mode OFF – Do not enter Flash Mode	No

Group.Step	Function	Possible Selections	Master Mode Access
<b>Group 3</b>		<b>Press Zero to Enter Press Tare to go to Group 4</b>	
3.1	Baud rate	0 – 1200 1 – 2400 2 – 4800 3 – 9600 4 – 19200 5 – 38400	Yes
3.2	Parity	0 – None 1 – Even 2 – Odd	Yes
3.3	Data	0 – 7 data bit 1 – 8 data bit	Yes
3.4	Bit stop	0 – None 1 – 1 stop bit 2 – 2 stop bit	Yes
3.5	Chose Protocol	0 = Disabled 1 = NCI-ECR (WO) 2 = (reserved) 3 = 8217 Mettler-Toledo (WO) 4 = 8213 Mettler-Toledo (WO) 5 = EPOS 1(WO) 6 = EPOS 2(WO) 7 = (reserved) 8 = Dialog 06 (PC) 9 = Dialog 04/02 (PC) 10 = (reserved) 11 = ICL (WO)	Yes
3.6	Inter-character Delay	0 – None 1 – 1 ms ... 9 – 9 ms	Yes
3.7	Protocol Options	<b>For NCI-ECR protocol,</b> 0 – 4 byte status reporting 1 – 2 byte status reporting	Yes
<b>Group 4</b>		<b>Press Zero to Enter Press Tare to go to EXIT</b>	
4.1	Weight Change	<b>00</b> - No Weight Change Required <b>yy</b> - 01 to 99 weight change divisions required	Yes
4.2	Return to Zero	<b>0</b> - No Return to Zero Required <b>1</b> - Return to Zero Active	Yes
<b>EXIT</b>		<b>Press Zero to Enter Press Tare to go to Group 1</b>	
SAVE	Save or abort setting	<b>SAVE</b> – save all settings and return to weighing mode <b>ABORT</b> – abort all settings and return to weighing mode	Yes

\* Used only on the 4 Line display

**PC** – Price Computing

**WO** – Weight Only



### 3.5 GeoCal® Country Codes

Country	Geo-Value
Austria	18
Belgium	21
Bulgaria	16
Croatia	18
Czechia	20
Denmark	23
Estonia	24
Finland	25* 26
France	17 19*
Germany	20
Greece	15
Hungary	19
Ireland	22
Iceland	26
Italy	17
Kazakhstan	18
Latvia	23
Luxemburg	20

Country	Geo-Value
Liechtenstein	18
Lithuania	22
Netherlands	21
Norway	24* 26
Poland	21
Portugal	15
Romania	18
Russia	23
Sweden	24* 26
Switzerland	18
Slovakia	19
Slovenia	18
Spain	15
Turkey	16
United Kingdom	21* 23
Ukraine	21

\* *Factory Default*

### 3.6 GeoCal® USA State Location Codes

State	Code
<b>Alabama</b> Birmingham & North South of Birmingham	13 12
<b>Alaska</b>	See map
<b>Arizona</b> Phoenix & North South of Phoenix	12 11
<b>Arkansas</b>	13
<b>California</b>	See map
<b>Colorado</b> Denver & North South of Denver	13 12
<b>Connecticut</b>	16
<b>Delaware</b>	15
<b>Florida</b> West Palm Beach & North South of West Palm Beach	11 10
<b>Georgia</b>	12
<b>Hawaii</b>	9
<b>Idaho</b> North of Salmon River Mtns South of Salmon River Mtns	17 16
<b>Illinois</b> Bloomington & North South of Bloomington	16 15
<b>Indiana</b> North of Indianapolis Indianapolis & South	16 15
<b>Iowa</b> North of Des Moines Des Moines & South	17 16
<b>Kansas</b>	14
<b>Kentucky</b>	14

State	Code
<b>Louisiana</b>	12
<b>Maine</b>	18
<b>Maryland</b>	15
<b>Massachusetts</b>	17
<b>Michigan</b> Northwest of Lake Southeast of Lake	18 17
<b>Minnesota</b>	18
<b>Mississippi</b> Kosciusko & North South of Kosciusko	13 12
<b>Missouri</b> North of Springfield Springfield & South	15 14
<b>Montana</b> Helena & North South of Helena	18 17
<b>Nebraska</b>	15
<b>Nevada</b>	13
<b>New Hampshire</b>	17
<b>New Jersey</b>	16
<b>New Mexico</b>	11
<b>New York</b> Albany & North South of Albany	17 16
<b>North Carolina</b> Raleigh & North South of Raleigh	14 13
<b>North Dakota</b>	18
<b>Ohio</b> Akron & North South of Akron	16 15

State	Code
<b>Oklahoma</b>	13
<b>Oregon</b> Salem & North Between Oakridge & Salem South of Oakridge	18 17 16
<b>Pennsylvania</b>	16
<b>Rhode Island</b>	16
<b>South Carolina</b>	13
<b>South Dakota</b>	17
<b>Tennessee</b>	13
<b>Texas</b> Northeast of Colorado River Southwest of Colorado River	12 11
<b>Utah</b>	13
<b>Vermont</b>	17
<b>Virginia</b>	14
<b>Washington, DC</b>	15
<b>Washington State</b>	18
<b>West Virginia</b>	15
<b>Wisconsin</b> Green Bay & North South of Green Bay	18 17
<b>Wyoming</b> North of Casper Casper & South	15 14



## 3.7 Calibration

**Note:** *These functions are directly related to the Weight & Measurement regulations in your country, therefore they are protected by a sealed calibration button. The button is located as shown below. For the scale to be usable in a legal for trade application, the button must be sealed as is shown in section 2 after the calibration is complete.*

To calibrate the scale, follow this sequence:

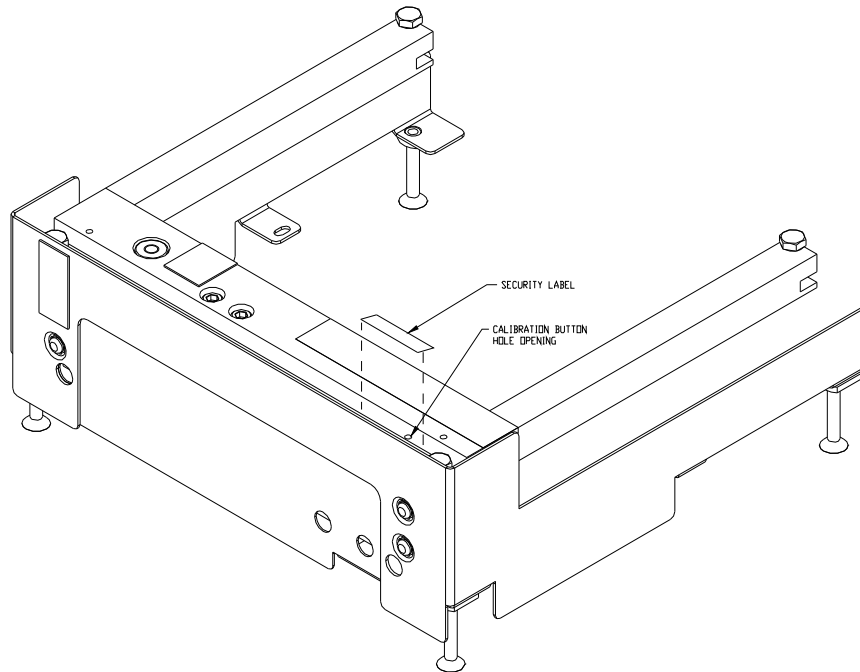

**Note:** *Be sure that the scale has been placed in an area free from air currents or excessive vibration. The platter should also be clean from any debris and ready for use. Check to make sure the scale has been leveled properly.*

1. Press the calibration button as is shown in section 3.1
2. Go to Group 2 Step 6 of the Service Mode (WO scale will show “26 no” on the display).
3. Press the Tare key to change the prompt to “Yes”.
4. Press the Zero key to accept.
5. The display will briefly be blank and then display “- - - -”
6. Clear the platter and Press the Zero key to accept the Zero Reading.
7. The display will now show “FULL CAP”
8. Place Full capacity onto the scale (30lb or 15kg)
9. Press the Zero key to accept.
10. The display will now show “NO LOAD”.
11. Remove all weights. Press the Zero key to take the final reading.



**Note: If the scale is unable to complete calibration it will display “E 20”. Cycle power to the scale and restart at Step 1 above.**

12. The scale will now save the calibration and cycle out of the Service mode and return to normal weighing mode.
13. Verify the calibration was successful with the calibrated weight. If for some reason the calibration was not successful, restart at Step 1.
14. If applicable, you should remove power from the scale and apply the appropriate calibration seal.
15. Place the scale into service!

<b>Calibration Quick Reference Chart</b>
<ol style="list-style-type: none"><li>1. Break the calibration seal and press the Calibration button.</li><li>2. Select “Yes” in Group 2, Step 6 of the Service Mode.</li><li>3. Empty the scale and take the no load reading.</li><li>4. Place Full Load on the scale and take the reading.</li><li>5. Save the settings and verify the calibration in normal weighing mode.</li></ol>

# 4 Operating Instructions

## 4.1 Displays

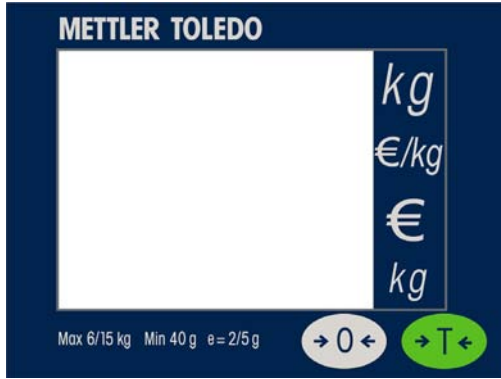

72190532

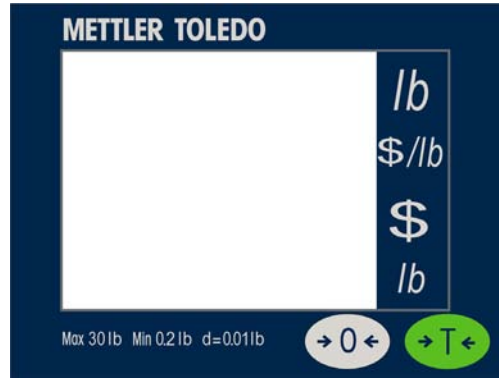

72190533



72187467



72187468





72188623



72190534

## 4.2 Keyboard

Key	Description
	Used to return the scale to gross zero.
	Tare key.

## 4.3 Cursors

Cursor	Description
NET	When tare is entered.
ZERO	When weight is gross zero.

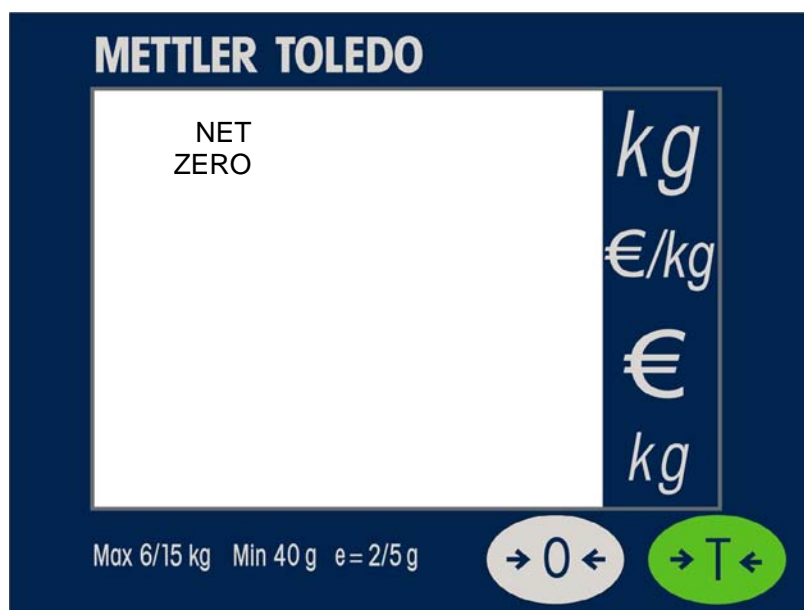

## 4.4 Operations

### 4.4.1 Weighing and Communication

Place the item to be weighed on the platter, the weight will be displayed.

Remote ASCII commands can control the scale through the provided RS232 port. Commands include zero, tare, and other data functions depending on the protocol. See Section 6 for available protocols and their descriptions.

### 4.4.2 Backlight function

DIVA is equipped with a backlight for the display. If ambient lighting conditions are not sufficient, the backlight can be switched on to easily read the display.

To activate, Press and hold the Zero Key for about three seconds until a long beep is heard and the backlight turns on.

Use the same procedure to switch the backlight off.

When the scale is not used for 1 minute, the backlight will automatically switch off. When weight is placed on the platter or a key is pressed, the backlight will switch on again.

### 4.4.3 Re-zero Functions

There are two ways to re-zero the scale:

#### **Power-up Zero**

The scale will automatically capture zero when it is turned on. The power-up zero capture range is +/-10% of the scale capacity. When the scale is turned on with a weight on the platter of more than +/-10% of the capacity, the scale will not capture zero and the weight display will show "-----". After removing the weight, the scale will capture "zero".

#### **Pushbutton Zero**

The Zero Key re-zeros the scale within the range of +/-2% of the scale capacity. To use this function, the scale must be in the gross weighing mode (NET cursor must be off) and in a no motion condition. When the weight on the platter is more than +/-2% of the scale capacity, pressing neither the Zero Key nor a remote ASCII Zero command will be accepted.

### 4.4.4 Tare Function

The Tare Key allows you to subtract weight from the platter for items like containers that will be used to hold the item being weighed.



Place the empty container or wrapping material on the platter and Press the Tare Key.



Place the item to be weighed in the container or on the wrapping material and onto the platter.

## 5 Service and Maintenance

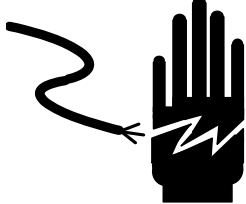
This chapter provides information on servicing and maintaining the scale including:

- Cleaning and regular maintenance
- Troubleshooting

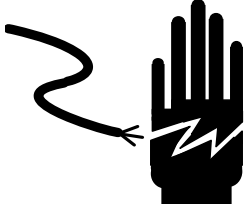
	 <b>WARNING</b>
	<p>ONLY PERMIT QUALIFIED PERSONNEL TO SERVICE THIS EQUIPMENT. EXERCISE CARE WHEN MAKING CHECKS, TESTS AND ADJUSTMENTS THAT MUST BE MADE WITH POWER ON. FAILING TO OBSERVE THESE PRECAUTIONS CAN RESULT IN BODILY HARM.</p>

	 <b>WARNING</b>
	<p>DISCONNECT ALL POWER TO THIS UNIT BEFORE SERVICING OR CLEANING.</p>

### 5.1 Cleaning and Regular Maintenance

Do not use any types of industrial solvents. These may damage the display and platter finish. Wipe the display area and weighing platter with a clean, soft cloth with water or a mild glass cleaner. Regular maintenance inspections by a qualified service technician are also recommended.

### 5.2 Troubleshooting

The following table lists error messages, descriptions, and corrective actions.

**Error Codes and Actions**

E 11	RAM error	Cycle power to the scale. For continued problems call METTLER TOLEDO for replacement
E 16	ROM error	
E 18	EEPROM error	
E 20	Calibration error	Cycle power to the scale and restart calibration.
E 28	Transmission Error	Reset Scale
nnnnnn in weight display	Over capacity	Remove weight from Platter, if that does not work try cycling the power to the scale. For continued problems call METTLER TOLEDO for replacement.
nnnnnn in total price display	Over 9999.99	
uuuuuu in weight display	Under zero	Place the platter on the scale. Either press the Zero Key or cycle power to the scale. For continued problems call METTLER TOLEDO for replacement.

## 5.3 Flash Updating the Software

The Diva's software can be flash updated through the serial communications port. You will need to have the standard Diva communications cable and access to the Internet for downloading the software flash tool and latest software. Please contact Mettler-Toledo, Inc. Technical Support for detailed instructions.

## 5.4 Connections to a POS

### 5.4.1 Communications Pinout

For communications with the scale, you will need the appropriate communications cable. This cable will have an RJ45 connector on one end that is plugged into the appropriate port on the scanner. The other end will be DB9-F and is used for plugging into the POS.

Diva DB9-F		
Pin#	Function	Description
2	TxD	Transmit Data
3	RxD	Receive Data
5	SGnd	Signal Ground

**Note:** *All other pins should not be connected.*

Should you need to construct your own communications cable. The following is the pinout on the Dual 5 Connector directly on the scale.

Dual 5 Connector Pin Descriptions and Positions				
(when looking directly at the pins)				
Pin 9 Status	Pin 7 RTS	Pin 5 TxD	Pin 3 +5V DC	Pin 1 +12V DC
Pin 10 Scale Zero	Pin 8 CTS	Pin 6 RxD	Pin 4 Gnd	Pin 2 Gnd

### 5.4.2 Handshaking

For PC DB25 serial port connector: Jumper 4 to 5, and 6, 8, & 20 together on the POS side.  
 For PC DB9 serial port connector: Jumper 4 to 6 and 7 to 8 together on the POS side.

# 5.5 Parts and Descriptions

General Exploded Diagram.

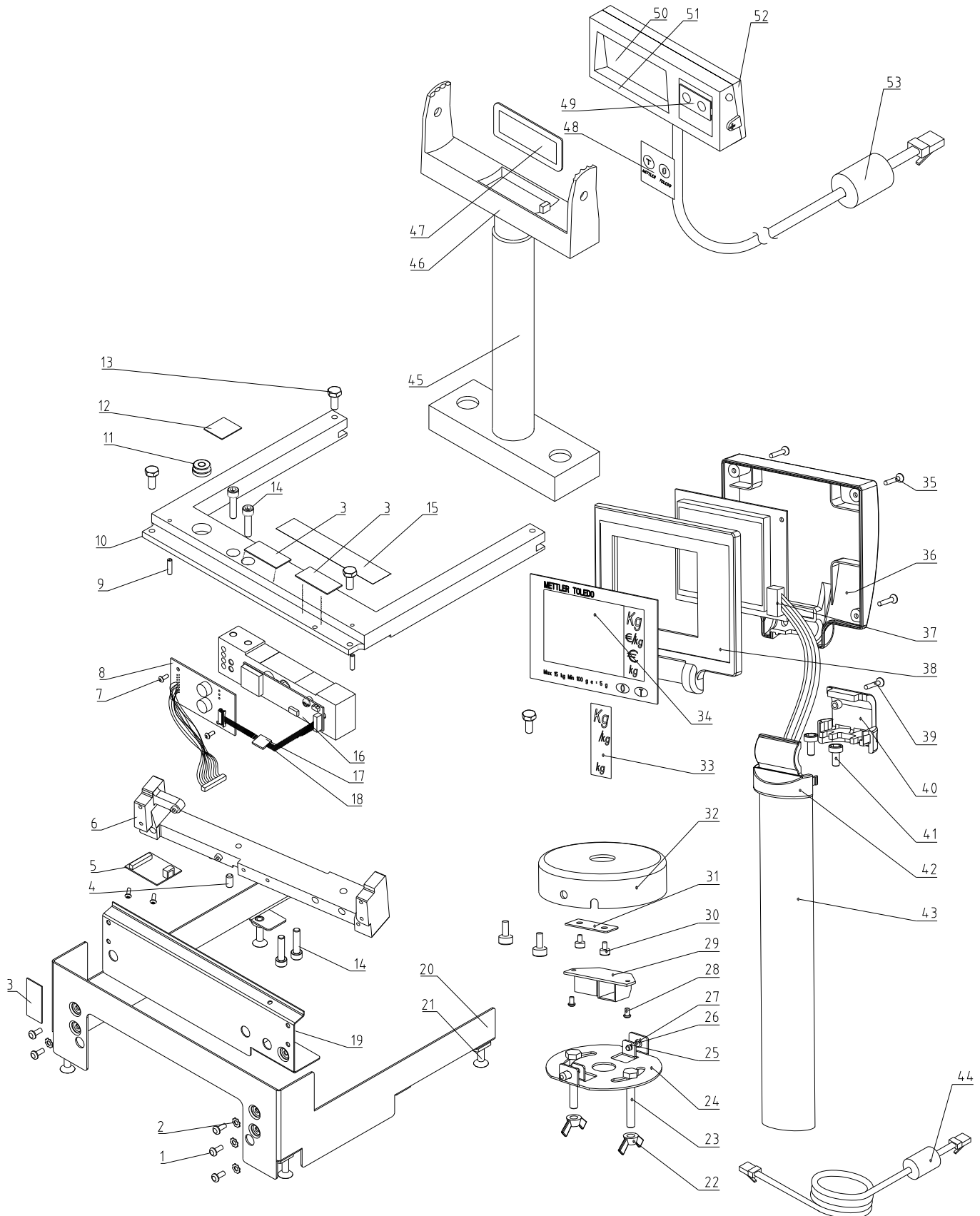









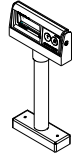
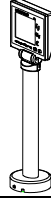

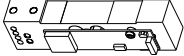
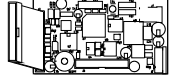

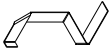
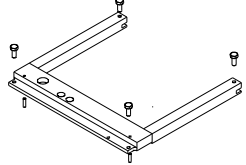

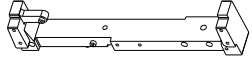
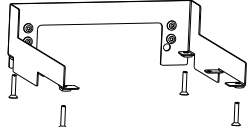
**Note:** Most parts are not available for individual replacement. This following chart and diagrams are only provided for reference.

ID	Description	ID	Description
1	SCR, PH HD, M4X10	28	SCREW, M4X6
2	WASHER, LOCK, STAR, #8	29	ASSY, PCB, ADAPTER
3	LABEL, SECURITY SEAL	30	SCREW, M4X4, SEALING
4	SCR, SET, M6X12, FT PT	31	FIXING PLATE, CABLE
5	ASSY, PCB, DIVA-PSC, INTERFACE	32	BASE, TOWER
6	BASE, PLATE, PSC DIVA	33	LENS STICKER
7	SCR, PH HD, M3X8	34	OVERLAY, DIVA
8	PSC ASSY, MAIN DIVA-PSC	35	SCREW, M2.9X9.5
9	SCR, SET, FL PT, M4X16	36	COVER, REAR, DISPLAY, VIVA
10	ASSY, SPIDER, DURA	37	ASSY, PCB, TOWER DISP, DIVA
11	LEVEL, BUBBLE, W/O AD	38	COVER, FRONT, DISPLAY
12	CAPACITY LABEL	39	SCREW, M2 9X19
13	SCR, HX HD, ¼-20X5/8	40	CIRCLE HOOP, FIXING HALF
14	SCR, HS HD, M6X25	41	SCREW, M5X10
15	DATA LABEL, VERTICAL	42	CIRCLE HOOP, COVER HALF
16	L/C, QUAL	43	TOWER
17	FERRITE, FLEX CIRCUIT	44	CABLE, DISPLAY, DIVA, 4M
18	CABLE, LAMINATED, ZIF	45	TOWER MOUNTING, DISPLAY
19	COVER, SCALE, DURA/DIVA	46	TOWER BASE, DISPLAY
20	ASSY, SCALE SURROUND	47	LENS, DISPLAY
21	FT, FH SCR, M6X35	48	KEYBOARD, DISPLAY
22	WING NUT, M6	49	KEYBOARD, MEMBRANE
23	SCREW, M6X45	50	ASSY, PCB, DISPLAY, SL
24	COVER, TOWER BASE	51	COVER, FRONT, DISPLAY
25	CIRCLIPS 3.2	52	COVER, REAR, DISPLAY
26	PIN	53	HARNESS, DISPLAY W/FERRITE
27	SPRING		



## 5.6 Replacement Parts Order Numbers

Part Number	Exploded ID	Description	Picture
72191106	45-53	SL DISP,W/LENS&CABLE,MT,24P	
72191107	22-44	4 Line, MT, €/KG, 6/15x.002/.005KG,15P	
72187468	47	Lens, MT, 1 Line, 30 x .01LB	See Section 4.1
72187467	47	Lens, MT, 1 Line, 6/15 x .002/.005KG	See Section 4.1
71209948	44	Display Cable, 4 meters	
72190451	Not Shown	CABLE,SCALE TO POS,DIVA	
42101395	16	Load Cell	
72190210	8	Diva Main PCB (PSC)	
72189582	5	Connector PCB (PSC)	
71208258	17	LC Flex Circuit	
72191215	10	Subplatter, PSC	
71208253	Not Shown	Power Supply, (PSC, same as Dura)	
71208254	Not Shown	Power Y-Cable, (PSC, same as Dura)	
72191407	6	Base Casting, PSC	
72191406	20	Outer Sheet Metal, PSC	
68001451	3	Paper Sealing Label	

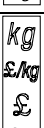
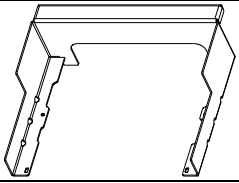
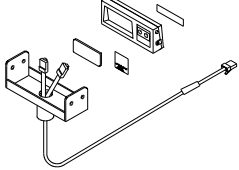
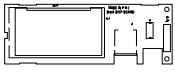
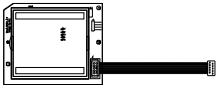
Part Number	Exploded ID	Description	Picture
71209398	Not Shown	Mounting Screw (PSC, same as Dura)	
72185768	33	Currency Sticker,Poland, 4 Line Display	
72185767	33	Currency Sticker,Czech, 4 Line Display	
72185766	33	Currency Sticker,Hungary, 4 Line Display	
71209973	33	Currency Sticker,Switzerland, 4 Line Display	
71209974	33	Currency Sticker,Venezuela, 4 Line Display	
71209972	33	Currency Sticker, \$/kg, 4 Line Display	
71209975	33	Currency Sticker,UK,kg, 4 Line Display	
72190532	34	overlay,4l display,MT diva,6/15kg	See Section 4.1
72190533	34	overlay,4l display,MT diva,30lb	See Section 4.1
72188623	47	lens,sl dsp,diva,15/30lb	See Section 4.1
72191211	Not Shown	Scale Cover Kit for PSC 8203	
72190534	47	overlay,sl display,MT diva	See Section 4.1
72191416	Not Shown	KIT,WO DUAL DISP,30X.01LB	
72191417	Not Shown	KIT,WO DUAL DISP,6/15kgX2/5g	
71209947	50	PCB, SINGLE LINE DISPLAY	
71209952	37	PCB, FOUR LINE DISPLAY	

---

## 6 Appendix

### 6.1 Protocols

The numbers correspond to the number that will show up in the Soft Switch settings in Group 3.5:

0. (Reserved)
1. NCI - ECR
2. (Reserved)
3. 8217 Mettler Toledo
4. 8213 Mettler Toledo
5. EPOS 1 (Weight Only)
6. EPOS 2 (Weight Only)
7. (Reserved)
8. Dialog 06
9. Dialog 04 / 02
10. (Reserved)
11. ICL

## 6.1.1 NCI – ECR

### 6.1.1.1 OVERVIEW

The serial communications protocol is used to interface Weigh-Tronix/NCI POS (Point-of-Sale) scales to ECR (Electronic Cash Registers), or other computing equipment (eg. personal computers).

Baud rate and parity will be configurable. Start and stop bits will each be fixed at one (1). Data bits will be fixed at seven.

Baud rates supported will be 1200, 2400, 4800, 9600 and 19200.

Responses to serial commands will be immediate, or within one weight meter cycle of the scale.

One second should be more than adequate for use as a time-out value by the remote (controlling) device.

There are two types of serial commands: *mandatory* and *optional*. Mandatory commands must be supported by all products.

If weight is negative, in motion, over capacity or under capacity, or if a zero error exists, only the scale's status is returned in response to a weight ('W') command.

Status bytes are prefaced by the letter 'S'

Units of measure abbreviations are always upper case.

The weight is always positive, therefore there is no polarity byte

Key to symbols used:

<ETX> End of TeXt character (03 hexadecimal).

<LF> Line Feed character (0A hex).

<CR> Carriage Return character (0D hex).

<SP> Space (20 hex).

x Weight characters from display including minus sign and out-of range characters.

hh Two status bytes.

UU Units of measure (LB, KG, OZ, G, etc., all upper case).

### Mandatory Commands

Name: Request weight

Command: W<CR>

Response: Returns decimal weight, units and status. (see note 1 and 2)  
<LF>xx.xxxUU<CR><LF>Shhhh<CR><ETX>

Returns lb-oz weight with units plus scale status.

<LF>xLB<SP>xx.xOZ<CR><LF>Shhhh<CR><ETX>

Scale status only if wt < 0, initial zero error, in motion or out of capacity.

<LF>Shhhh<CR><ETX>

Name: Request status

Command: S<CR>

Response: Returns scale status.  
<LF>Shhhh<CR><ETX>

Name: Zero the scale  
 Command: Z<CR>  
 Response: Scale is zeroed, returns scale status. (see note 4)  
 <LF>Shhhh<CR><ETX>

### Optional Commands

Name: Request high-resolution weight  
 Command: H<CR>  
 Response: Returns decimal wt in 10x with units plus scale status. (see notes 2 and 3)  
 <LF>xxx.xxxUU<CR><LF>Shhhh<CR><ETX>

Returns lb-oz wt in 10x with units plus scale status.  
 <LF>xLB<SP>xx.xxOZ<CR><LF>Shhhh<CR><ETX>

Scale status only if wt < 0, initial zero error, in motion or out of capacity.  
 <LF>Shhhh<CR><ETX>

Name: Change units of measure  
 Command: U<CR>  
 Response: Changes units of measure, returns new units and scale status.  
 <LF>uu<CR><LF>Shhhh<CR><ETX>

Name: Request metrology raw counts  
 Command: M<CR>  
 Response: Returns normalized raw counts and scale status.  
 <LF>xxxxxxMM<CR><LF>Shhhh<CR><ETX>

Name: unrecognized command  
 Command: all others  
 Response: Unrecognized command  
 <LF>?<CR><ETX>

#### NOTES:

- 1) Weight field is always six characters (5 for weight, 1 for decimal point), regardless of display size.
- 2) Leading zeroes are not suppressed.
- 3) High resolution weight field is seven characters (6 for weight, 1 for decimal point), regardless of display size.
- 4) If scale is outside zero range or in motion the 'Z' command is ignored and scale status is returned without zero status flag set, i.e., scale not at zero.

**Weight Command: W**

This command causes the scale to return the displayed weight string in ECR format. The scale will usually return the displayed weight with leading zeroes (ie no leading zero suppression). However, if weight is negative, in motion, over capacity or under capacity, or if a zero error exists, the ECR protocol causes only the scale's status to be returned in response to a weight ('W') command.

The returned weight string will include decimal point plus units of measure. The length of the weight field will be equal to the length of the scale's display plus three (one for the decimal point, and two for the units, e.g., "LB"). For pounds-ounce weight, the length of the weight field will be equal to the length of the scale's display plus five (one for the decimal point, two for the "LB" and two for the "OZ"). Units of measure will appear in their ANSI standard abbreviated form ("LB" for pounds, "KG" for kilograms, etc.) in uppercase characters.

**Zero Command: Z**

If zeroing criteria are met, the scale is zeroed. In any case, scale status is returned.

**High-Resolution Command: H**

This is the same as the **W** command except that when weight is returned, it is returned with ten times the scale's displayed resolution.

**Change Units Command: U**

The effect of this command will be the same as if the *UNITS* key on the scale were pressed, causing the scale to change its units of measure. In response, the scale will return the new units of measure and scale status.

**Metro Command: M**

This command is optional. It will cause the scale to return normalized raw counts used for metrology verification. The count value is the same number displayed in the scale's division test in its diagnostics mode. For example, this number ranges up to 120,000 for the 67xx, 100,000 for the 78xx and 1,000,000 for QDT scales.

**Scale Status Command: S**

There will be at least two status bytes. If bit 6 of the second status byte is set then there will be a third byte. Bit 6 of each successive byte will indicate whether or not another status byte follows. The bit will be clear (0) in the last status byte. At this time only the first three bytes are defined. Others may be added in the future. Bit 0 is the least significant bit in the byte while bit 7 is the most significant bit.

The status bits are defined as follows:

Bit	Status Byte 1	Status Byte 2	Status Byte 3	Status Byte 4
0	1 = Scale in motion 0 = Stable	1 = Under capacity 0 = Not under capacity	00 = Low range 01 = (undefined) 10 = (undefined) 11 = High range	1 = Weight Change 0 = No Change
1	1 = Scale at zero 0 = Not at zero	1 = Over capacity 0 = Not over capacity		1 = Zero Detected 0 = No Zero Seen
2	1 = RAM error 0 = RAM okay	1 = ROM error 0 = Calibration okay	1 = Net weight 0 = Gross weight	1 = Metric 0 = English
3	1 = EEPROM error 0 = EEPROM okay	1 = Faulty calibration 0 = Calibration okay	Initial zero error	Unused
4	<b>Always 1</b>	<b>Always 1</b>	<b>Always 1</b>	<b>Always 1</b>
5	<b>Always 1</b>	<b>Always 1</b>	<b>Always 1</b>	<b>Always 1</b>
6	<b>Always 0</b>	1 = Byte follows 0 = Last byte	1 = Byte follows 0 = Last byte	1 = Byte follows 0 = Last byte
7	Parity	Parity	Parity	Parity

## 6.1.2 (Reserved)



## 6.1.3 8217 Mettler Toledo

### 6.1.3.1 Host Communications

The 8217 scale acts as a peripheral device when connected to a host computer. When the host requests weight data by sending an uppercase **W**, the scale will respond with the weight data or a status byte if the scale is in motion or an invalid state. The host can also request a scale zero operation, in which case the scale will respond with the scale status, so the host can determine if the scale is in zeroing range and/or if the scale is at zero. A scale confidence test can also be initiated by the host to cause the scale to perform RAM, ROM, and NOVRAM tests and put the results in a status byte for later interrogation by the host.

Data is transmitted and received by the scale using an RS232 voltage level interface in the following ASCII format: 7 bit even parity and one stop bit. Data transmission rates are 1200, 2400, 9600, or 19200 baud asynchronous. The host computer must send requests to the scale as specified single uppercase ASCII characters to have it perform various functions. The scale will send a response back to the host computer as a string of ASCII numeric digits or as an ASCII **?** followed by a status byte. There must be at least a 200-ms delay between commands to allow for processing data response time at the scale. The following table shows the standard commands and responses between the scale and host. If a confidence test results in an error, the scale will not respond to the **W** or **Z** commands until the error condition is corrected. An error will also cause the scale to halt any weighing operation until cleared.

6.1.3.2 Command Descriptions

**ASCII Commands**  
 (\* MUST BE UPPERCASE CHARACTERS ONLY.)

*ASCII Command From Host	Scale Response	Description
<b>W</b>	STX WW.WW <sup>C<sub>R</sub></sup> STX WW.WWW <sup>C<sub>R</sub></sup> STX WW.WWN <sup>C<sub>R</sub></sup> STX WW.WWWN <sup>C<sub>R</sub></sup> STX?status byte <sup>C<sub>R</sub></sup>	Instructs scale to send weight data. (W=Weight Digit 0-9). The scale will respond as follows according to setup and status:  Gross Weight Pounds. Gross Weight KG. Net Weight Pounds. ASCII N added after weight. Net Weight KG. ASCII N added after weight. Status byte is sent if scale is in motion, or is net/gross weight is negative or over capacity. Table "Scale Status Byte Bit Definitions" to determine status byte results.
<b>Z</b>	STX?status byte <sup>C<sub>R</sub></sup>	Zero scale command. On the next A/D reading, zero will be captured if the weight is stable, within capture range, and no tare is taken (gross weight mode.)
<b>T</b> <sup>C<sub>R</sub></sup>	STX?status byte <sup>C<sub>R</sub></sup>	Tare item on platter command. The scale must be at gross zero before placing the item on the platter. Tare will be taken if weight is stable and non-zero. After 150 millisecond delay, the scale will respond with a status byte. (NOTE: Tare must be enabled in calibration mode or scale will not respond.)
<b>TWWWWW</b> <sup>C<sub>R</sub></sup>	STX?status byte <sup>C<sub>R</sub></sup>	Digital Tare Command. Known tare value can be sent to scale and must be transmitted as five digits. The scale assumes a decimal point of WWW.WW LB, or WW.WWW KG. (Note: Tare must be enabled in calibration mode or scale will not respond.)
<b>C</b>	STX?status byte <sup>C<sub>R</sub></sup>	Clear Tare Command (ignored if weight is not stable.) Scale status byte is sent after 150 ms delay.
<b>A</b>	STX <sup>C<sub>R</sub></sup>	Initiate Confidence Test Command. STXCR is sent indicating command was received.
<b>B</b>	STX?status byte <sup>C<sub>R</sub></sup>	Send Confidence Test Results Command. <b>A</b> must be sent prior to the Send Result command <b>B</b> . Results of the test are contained in a status byte. Use Table 12-c to determine test results. If all tests passed, the ASCII @ character will be returned.
<b>E</b>	STXE <sup>C<sub>R</sub></sup>	Start Echo Mode Serial Port Test Command. Scale will respond with an E indicating command received. Characters except F will be echoed back to the host.
<b>F</b>	STXF	End Echo Mode Command. The scale will respond with an ASCII <b>F</b> indicating the command was received.

### 6.1.3.3 Status Byte Format

When the scale responds with STX?status byte<sup>C<sub>R</sub></sup>, this indicates a status byte. The status byte contains scale status information, which can include net/gross mode, zero status, etc. The actual status byte sent will be an ASCII character which must be converted to binary to decode the bits. The scale status bit definitions are shown in the following table.

**Scale Status Byte Bit Definitions**

Bit Number	Bit Description
7	7 Parity Bit (even).
6	1 = Normal. 0 = Bad Command from host.
5	1 = Net Weight, 0 = Gross Weight
4	1 = Center of zero. 0 = Not at center of zero.
3	1 = Outside zero capture range. 0 = Within range.
2	1 = Under zero. 0 = Within weighing range.
1	1 = Over capacity. 0 = Within weighing range.
0	1 = Scale in motion. 0 = Stable weight data.

### 6.1.3.4 Confidence Test Status Byte Format

When the scale responds with STX? *status byte*<sup>C<sub>R</sub></sup>, after requesting a confidence test (B), a confidence test status byte will be sent. The status byte contains scale status information, which can include net/gross mode, zero status, etc. The actual status byte sent will be an ASCII character which must be converted to binary to decode the bits. The confidence test status bits are shown in the following table. Bit 6 is set to 1 after a confidence test is performed and reset to 0 after the host reads the confidence test status byte. The Confidence Test Byte bit definitions are shown below.

Note: The ASCII @ (decimal 64) indicates all tests were passed. Repeated reads of the confidence byte for all test passed without initiating a new confidence test will result in an ASCII NULL (hex 00).

**Scale Confidence Test Byte Bit Definitions**

Bit Number	Bit Description
7	Parity Bit (even).
6	1 = New status data available. 0 = Host has read data.
5	Bit is always a 0.
4	1 = ROM test failed. 0 = ROM test passed.
3	1 = Processor RAM test failed. 0 = Processor RAM test passed.
2	1 = Ram Test Passed. 0 = Ram Test Failed.
1	1 = NOVROM test failed. 0 = NOVROM test passed.
0	Always 0.

### 6.1.3.5 Tare

Tare can be taken on an item two ways: Automatic or digital.

#### REMOTE TARE

The unknown weight of an object can be tared-off automatically by placing the object on the scale platter, then with the display in a stable non-motion and positive weight condition, sending an uppercase ASCII *T* character followed by  $C_R$  from the host will automatically subtract the weight. The tare function must be enabled. Chain tare is not permitted. A display triangle, located under the least significant weight digit on the scale display will illuminate to indicate net weight is displayed. Negative weight will cause dashes to be displayed and status byte will be sent to the host instead of weight data.

#### DIGITAL TARE

Keyboard tare is set in the scale when an uppercase ASCII *T* character, followed by five ASCII digits and a CR is sent by the host. The scale weight display must be positive and stable. The tare value input is limited to the scale capacity. In metric mode, the tare value must always end in 0 or 5.

#### CLEARING TARE

If auto tare clear is enabled, tare is automatically cleared whenever the scale returns to gross zero after having indicated a stable net weight at least one increment above net zero. If auto tare clear is disabled, tare can be cleared by sending an uppercase ASCII *C* from the host.

## 6.1.4 8213 Mettler Toledo

### 6.1.4.1 Host Communications

The 8217 scale acts as a peripheral device when connected to a host computer. When the host requests weight data by sending an uppercase **W**, the scale will respond with the weight data or a status byte if the scale is in motion or an invalid state. The host can also request a scale zero operation, in which case the scale will respond with the scale status, so the host can determine if the scale is in zeroing range and/or if the scale is at zero. A scale confidence test can also be initiated by the host to cause the scale to perform RAM, ROM, and NOVRAM tests and put the results in a status byte for later interrogation by the host.

Data is transmitted and received by the scale using an RS232 voltage level interface in the following ASCII format: 7 bit even parity and one stop bit. Data transmission rates are 1200, 2400, 9600, or 19200 baud asynchronous. The host computer must send requests to the scale as specified single uppercase ASCII characters to have it perform various functions. The scale will send a response back to the host computer as a string of ASCII numeric digits or as an ASCII **?** followed by a status byte. There must be at least a 200-ms delay between commands to allow for processing data response time at the scale. The following table shows the standard commands and responses between the scale and host. If a confidence test results in an error, the scale will not respond to the **W** or **Z** commands until the error condition is corrected. An error will also cause the scale to halt any weighing operation until cleared.

## 6.1.4.2 Command Descriptions

**ASCII Commands**  
 (\* MUST BE UPPERCASE CHARACTERS ONLY.)

*ASCII Command From Host	Scale Response	Description
<b>W</b>	STX 0WW.WW <sup>C<sub>R</sub></sup> STX WW.WWW <sup>C<sub>R</sub></sup> STX 0WW.WWN <sup>C<sub>R</sub></sup> STX WW.WWWN <sup>C<sub>R</sub></sup> STX?status byte <sup>C<sub>R</sub></sup>	Instructs scale to send weight data. (W=Weight Digit 0-9). The scale will respond as follows according to setup and status:  Gross Weight Pounds. Gross Weight KG. Net Weight Pounds. ASCII N added after weight. Net Weight KG. ASCII N added after weight. Status byte is sent if scale is in motion, or is net/gross weight is negative or over capacity. Table "Scale Status Byte Bit Definitions" to determine status byte results.
<b>Z</b>	STX?status byte <sup>C<sub>R</sub></sup>	Zero scale command. On the next A/D reading, zero will be captured if the weight is stable, within capture range, and no tare is taken (gross weight mode.)
<b>T<sup>C<sub>R</sub></sup></b>	STX?status byte <sup>C<sub>R</sub></sup>	Tare item on platter command. The scale must be at gross zero before placing the item on the platter. Tare will be taken if weight is stable and non-zero. After 150 millisecond delay, the scale will respond with a status byte. (NOTE: Tare must be enabled in calibration mode or scale will not respond.)
<b>TWWWWW<sup>C<sub>R</sub></sup></b>	STX?status byte <sup>C<sub>R</sub></sup>	Digital Tare Command. Known tare value can be sent to scale and must be transmitted as five digits. The scale assumes a decimal point of WWW.WW LB, or WW.WWW KG. (Note: Tare must be enabled in calibration mode or scale will not respond.)
<b>C</b>	STX?status byte <sup>C<sub>R</sub></sup>	Clear Tare Command (ignored if weight is not stable.) Scale status byte is sent after 150 ms delay.
<b>A</b>	STX <sup>C<sub>R</sub></sup>	Initiate Confidence Test Command. STXCR is sent indicating command was received.
<b>B</b>	STX?status byte <sup>C<sub>R</sub></sup>	Send Confidence Test Results Command. <b>A</b> must be sent prior to the Send Result command <b>B</b> . Results of the test are contained in a status byte. Use Table "Scale Confidence Test Byte Bit Definitions" to determine test results. If all tests passed, the ASCII @ character will be returned. If a confidence test results in an error, the scale will not respond to the "W", "H", or "Z" command until the error condition is cleared. A confidence test error will also cause the scale weighing operation to halt until the error condition is cleared.
<b>E</b>	STXE <sup>C<sub>R</sub></sup>	Start Echo Mode Serial Port Test Command. Scale will respond with an E indicating command received. Characters except F will be echoed back to the host.
<b>F</b>	STXF	End Echo Mode Command. The scale will respond with an ASCII F indicating the command was received.

### 6.1.4.3 Status Byte Format

When the scale responds with STX? *status byte* <sup>C<sub>R</sub></sup>, this indicates a status byte. The status byte contains scale status information, which can include net/gross mode, zero status, etc. The actual status byte sent will be an ASCII character which must be converted to binary to decode the bits. The scale status bit definitions are shown in the following table.

**Scale Status Byte Bit Definitions**

Bit Number	Bit Description
7	7 Parity Bit (even).
6	Always 1
5	1 = Net Weight, 0 = Gross Weight
4	1 = Center of zero. 0 = Not at center of zero.
3	1 = Outside zero capture range. 0 = Within range.
2	1 = Under zero. 0 = Within weighing range.
1	1 = Over capacity. 0 = Within weighing range.
0	1 = Scale in motion. 0 = Stable weight data.



#### 6.1.4.4 Confidence Test Status Byte Format

When the scale responds with STX? *status byte*<sup>C<sub>R</sub></sup>, after requesting a confidence test (B), a confidence test status byte will be sent. The status byte contains scale status information, which can include net/gross mode, zero status, etc. The actual status byte sent will be an ASCII character which must be converted to binary to decode the bits. The confidence test status bits are shown in the following table. Bit 6 is set to 1 after a confidence test is performed and reset to 0 after the host reads the confidence test status byte. The Confidence Test Byte bit definitions are shown below.

Note: The ASCII @ (decimal 64) indicates all tests were passed. Repeated reads of the confidence byte for all test passed without initiating a new confidence test will result in an ASCII NULL (hex 00).

**Scale Confidence Test Byte Bit Definitions**

Bit Number	Bit Description
7	Parity Bit (even).
6	1 = New status data available. 0 = Host has read data.
5	Bit is always a 0.
4	1 = ROM test failed. 0 = ROM test passed.
3	1 = Processor RAM test failed. 0 = Processor RAM test passed.
2	1 = Ram Test Passed. 0 = Ram Test Failed.
1	1 = NOVROM test failed. 0 = NOVROM test passed.
0	Always 0.

## 6.1.5 EPOS 1

### 6.1.5.1 Data Format

2400 Baud (select 2400, 4800 or 9600)

7 data bits (select 7 or 8)

Even parity (select Even, None or Odd parity)

1 stop bit (select 1 or 2 stop bit)

### 6.1.5.2 Command Descriptions

Command	COMMENTS																			
ENQ (05h)	Starts the communication sequence																			
ACK (06h)	Data Available																			
CAN (18h)	Repeat weighing																			
NAK (15h)	No acknowledgement																			
NUL (00h)	No data available																			
DC1 (11h)	Data Request																			
STX (02h)	Start of text																			
ID	<p>Information byte, broken down into the following bits:</p> <table border="1"> <thead> <tr> <th colspan="3">Bit</th> <th rowspan="2">Capacity</th> </tr> <tr> <th>2</th> <th>1</th> <th>0</th> </tr> </thead> <tbody> <tr> <td>0</td> <td>0</td> <td>1</td> <td>15kg x 0.005kg</td> </tr> <tr> <td>0</td> <td>1</td> <td>0</td> <td>30lb x 0.01lb</td> </tr> <tr> <td>0</td> <td>1</td> <td>1</td> <td>6kg x 0.002kg</td> </tr> </tbody> </table> <p> <b>Bit 3</b> - Logic 1  <b>Bit 4</b> - Logic 1 means under/over range  <b>Bit 5</b> - Logic 1  <b>Bit 6</b> - Logic 1 indicates non-AVR capacities                 </p>	Bit			Capacity	2	1	0	0	0	1	15kg x 0.005kg	0	1	0	30lb x 0.01lb	0	1	1	6kg x 0.002kg
Bit			Capacity																	
2	1	0																		
0	0	1	15kg x 0.005kg																	
0	1	0	30lb x 0.01lb																	
0	1	1	6kg x 0.002kg																	
Weight	5 bytes with MSD first																			
BCC	Block Check Character calculated as the even column parity (Longitudinal Redundancy Check) of all characters except the STX and ETX.																			
ETX (03h)	End of text																			
STX Z NUL NUL NUL NUL NUL ETX BCC	Command String to Zero the scale from the EPOS, note that the BCC in this case will be "Z"																			
STX N NUL NUL NUL NUL NUL NUL ETX BCC	Command String to Tare the scale from the EPOS, note that the BCC in this case will be "N"																			
CR (0dh)	Data received and compared correctly																			

### 6.1.5.3 Command Flow

ECR	Scale	COMMENTS
ENQ (05h)		
	ACK (06h)	Data Available. Errors could be: CAN - repeat weighing NAK - no acknowledgement NUL - no data available
DC1 (11h)		Data Request Errors could be: NAK – no acknowledgement
	STX ID W5W4W3W2W1 BCC ETX	Transmitted Data
STX ID W5W4W3W2W1 BCC ETX		Confirm Data Errors could be: ACK – Data not confirmed
	CR (0dh)	Data confirmed

**Note:** Spaces depicted in the description above are only used for ease of reading. No space characters are used unless the BCC result yields the space character.

## 6.1.6 EPOS 2

### 6.1.6.1 Data Format

2400 Baud (select 2400, 4800 or 9600)

7 data bits (select 7 or 8)

Even parity (select Even, None or Odd parity)

1 stop bit (select 1 or 2 stop bit)

### 6.1.6.2 Handshaking

For PC DB25 serial port connector: Jumper 4 to 5, and 6, 8, & 20 together.

For PC DB9 serial port connector: Jumper 4 to 6 and 7 to 8.

### 6.1.6.3 Command Descriptions

Command	COMMENTS																			
ENQ (05h)	Starts the communication sequence																			
ACK (06h)	Data Available																			
NAK (15h)	No acknowledgement																			
NUL (00h)	No data available																			
DC1 (11h)	Data Request																			
STX (02h)	Start of text																			
ID	Information byte, broken down into the following bits: <table border="1" style="margin-left: auto; margin-right: auto;"> <thead> <tr> <th colspan="3">Bit</th> <th rowspan="2">Capacity</th> </tr> <tr> <th>2</th> <th>1</th> <th>0</th> </tr> </thead> <tbody> <tr> <td>0</td> <td>0</td> <td>1</td> <td>15kg x 0.005kg</td> </tr> <tr> <td>0</td> <td>1</td> <td>0</td> <td>30lb x 0.01lb</td> </tr> <tr> <td>0</td> <td>1</td> <td>1</td> <td>6kg x 0.002kg</td> </tr> </tbody> </table> <p> <b>Bit 3</b> - Logic 1  <b>Bit 4</b> - Logic 1 means under/over range  <b>Bit 5</b> - Logic 1  <b>Bit 6</b> - Logic 1 indicates non-AVR capacities                 </p>	Bit			Capacity	2	1	0	0	0	1	15kg x 0.005kg	0	1	0	30lb x 0.01lb	0	1	1	6kg x 0.002kg
Bit			Capacity																	
2	1	0																		
0	0	1	15kg x 0.005kg																	
0	1	0	30lb x 0.01lb																	
0	1	1	6kg x 0.002kg																	
Weight	5 bytes with MSD first																			
BCC	Block Check Character calculated as the even column parity (Longitudinal Redundancy Check) of all characters except the STX and ETX.																			
ETX (03h)	End of text																			
STX Z NUL NUL NUL NUL NUL ETX BCC	Command String to Zero the scale from the EPOS, note that the BCC in this case will be "Z"																			
STX N NUL NUL NUL NUL NUL ETX BCC	Command String to Tare the scale from the EPOS, note that the BCC in this case will be "N"																			

#### 6.1.6.4 Command Flow

ECR	Scale	COMMENTS
ENQ (05h)		
	ACK (06h)	Data Available. Errors could be: CAN - repeat weighing NAK - no acknowledgement NUL - no data available
DC1 (11h)		Data Request Errors could be: NAK – no acknowledgement
	STX ID W5W4W3W2W1 BCC ETX	Transmitted Data

**Note:** Spaces depicted in the description above are only used for ease of reading. No space characters are used unless the BCC result yields the space character.

## 6.1.7 (Reserved)

## 6.1.8 Dialog 06

With free programmable POS-Systems it is for a third party on principle possible, to manipulate parts of the software, which are obligate to verification.

For this reason certifying agencies expects appropriate protection against such inadmissible manipulations of third parties.

A protection against manipulations presents the Checkout-Dialogue 06 in conjunction with precautions taken at the POS-Software.

### 6.1.8.1 POS-Software

The parts of the POS-Software, which are obligated to verify, have to be protected with checksums (here called value CS), created by an appropriate method (for instance CRC16). These checksums CS have also to be protected with checksums (here called value KW), created by the CRC16-method in use with a polynomial P, which is known only by the manufacturers of the scale and the POS-system. CS and KW both have a length of 16 bit.

Remark: KW represents the rest of the polynomial-division  $CS / P$ .

### 6.1.8.2 Checkout-Dialogue 06

The checkout-dialogue 06 presents for the scale the possibility, to request 1-5 pairs of values CS/KW in cyclic intervals from the POS-system and check their validity. In case of invalidity, no weight-results will be given from the scale to the POS-system, i.e. dealing with the scale is not possible. With the request for the checksums, the scale sends a random number, which has to be used from the POS-system for encoding the checksums. This shall prevent a third party from monitoring valid checksums with simple measures. The random number is an 8-bit-number, the higher nibble (here called Z1) is used for encoding the CS-values, and the lower nibble (here called Z2) is used for encoding the KW-values. The encoding of the CS-values has to be made by rotating them to the left for Z1 bits, the encoding of the KW-values by rotating them to the right for Z2 bits.

For checking the conformity of the used protocol version in POS-system and scale, the Checkout-Dialogue 06 presents for the POS-system the possibility to order the scale to display the version number of the protocol. If the POS-system also displays the version number, the conformity can be checked.





### Records for Communications from the Scale to a POS system

**Record 02:** Result of weighing (answer to records 01, 03, 04, 05)

STX 02 ESC X ESC D4 D3 D2 D1 D0 ESC D5 D4 D3 D2 D1 D0 ESC D5 D4 D3 D2 D1 D0 ETX

Record No.      status      scale-weight 5 digits      unit price 5/6 digits      price to pay 6 digits

Scale status  
 30H = lb. : oz / 1/8 oz  
 31H = lb. / 0,01  
 32H = lb. / 0,005  
 33H = kg

**Record 09:** Status information (answer to Record 08)

STX 09 ESC S1 S0 ETX

Record No.

- 00 no error
- 01 general error
- 02 parity error or buffer overflow
- 10 invalid record no.
- 11 invalid unit price
- 12 invalid tare value
- 13 invalid text
- 20 scale is still in motion (no standstill)
- 21 scale wasn't in motion since last operation
- 22 measurement is not yet finished
- 30 weight is less than minimum weight
- 31 scale is less than 0
- 32 scale is overloaded

**Record 11:** Request of checksums (or answer to Record 10)

STX 11 ESC D0 Z ETX

Record No.

- random number (only if D0 = 32H)
- 30H = checksums invalid
- 31H = checksums valid
- 32H = answer with rec. 10, use random number Z

Representation of random number Z like checksums (hexadecimal ASCII-char)

#### 6.1.8.4 Description of the Dialog

A dialogue will always be initiated by the POS-system.

##### Description of weighing operation

The POS-system transmits one of the **Records 01, 03, 04 or 05**.

The scale answers (if no errors) with **ACK** and displays the transmitted data. The POS-system now can request the weighing result from the scale by transmitting **EOT ENQ**. If the result is known the scale answers with **Record 02**.

If there is an error, the scale answers with **NAK**. The cause of the error can be explained by the POS-system sending **Record 08** and receiving **Record 09**. If the status is 20 or 22, the weighing results can be requested again by retransmitting **EOT ENQ**. In the case of other errors, the operation has to be started at the beginning (records 01, 03, 04 or 05).

##### Description of weighing operation with request of checksums

At certain times, the scale will request from the POS-system the calculation and transmitting of checksums. This will happen in the course of a weighing operation after receiving of one of the records 01, 03, 04 or 05, and happens if one of the following events occurs:

- the scale was just powered on
- there was an error detected before
- 50 weighing operations have taken place
- the version number was displayed by the scale (record 20)

##### Order of events:

- The POS-system transmits one of the **Records 01, 03, 04 or 05**.
- The scale answers with **Record 11**.
- Example: STX 11 ESC 247 ETX (transmit record 10, use random number 47H)
- The POS-system now calculates the checksums, encodes and transmits them by **record 10** to the scale.
- The scale responds Record 10 first with **ACK**.
- The POS-system continues as with a normal weighing operation by transmitting **EOT ENQ**.
- Only now the scale responds the validity of the checksums by **Record 11**.
- If the checksums were valid, the scale transmits STX 11 ESC 1 ETX otherwise STX 11 ESC 0 ETX.
- Regardless whether the response was positive or negative, the POS-system has to repeat the original weighing operation.

##### Status information

The POS-system is able to get status information from the scale by record 08.

##### Version number on/off

The POS-system can display the version number of the software in the scale. If the scale receives record 20 EOT STX 20 ESC 1 ETX, it will display the version number until it receives EOT STX 20 0 ETX. All other records will be ignored in between!

Please note that all dialogues must be initiated by the POS-system with **EOT**, **and** also every response of the scale has to be answered by the POS-system with **EOT** !

### 6.1.8.5 Flow Chart

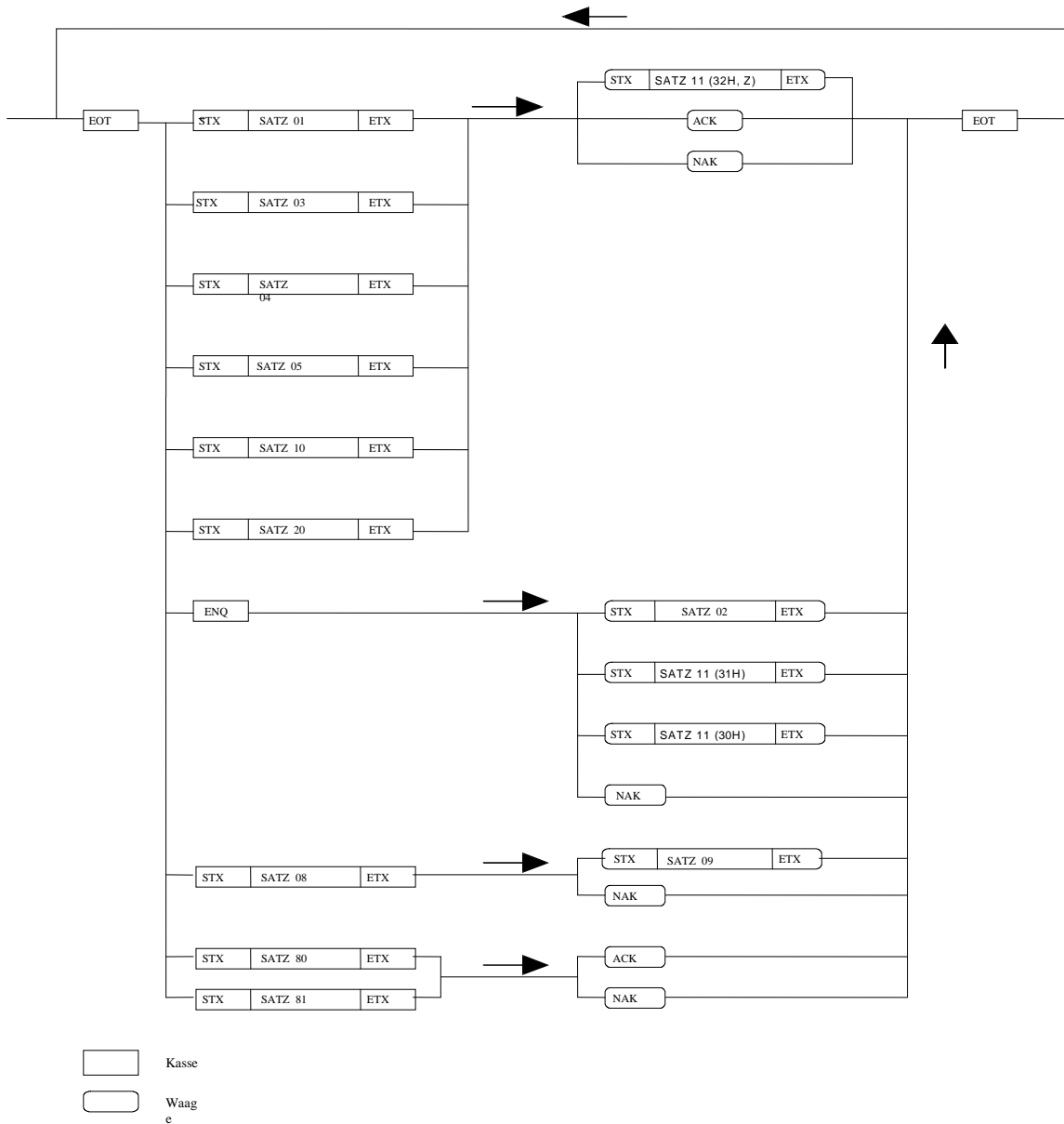

### 6.1.8.6 Data Format

Baud rate: 9600 Baud  
 Type of transmission: asynchronous  
 Data format: 7 Bit + Parity  
 Parity: odd  
 Stop bit: 1 Bit

### 6.1.9 Dialog 04 / 02

**Note:** To use Dialog 04, select this protocol but set the baud rate to 4800, for Dialog 02 the baud rate is set to 2400

#### 6.1.9.1 Data Format

Baud rate: 2400 Baud  
 Type of transmission: asynchronous  
 Data format: 7 Bit + Parity  
 Parity: odd  
 Stop bits: 1 Bit  
 Connection

	<b>Scale</b>	<b>POS</b>
	TXD 3	2 RXD
	RXD 2	3 TXD
	GND 5	5 GND

#### 6.1.9.2 Flow Chart

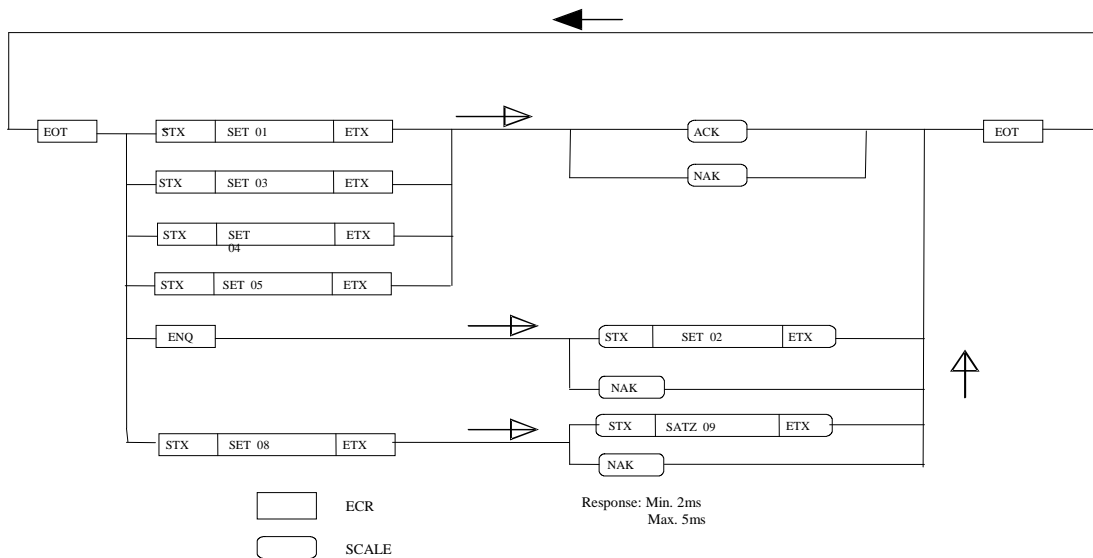

**Note:** The scale replies to ENQ with NAK when there is no load on the platter, the scale is in motion, under zero, or overcapacity. NAK is sent in response to the setting strings if there is invalid data in the setting.

### 6.1.9.3 Command Descriptions

#### POS System Communications to a Scale

<b>Setting number 01 - Basic Price</b>																			
EOT	STX	30h	31h	ESC	D5	D4	D3	D2	D1	D0	ESC	ETX							
		Setting number (01)			Basic Price 6 digits														
<b>Setting number 03: Basic Price, Tare Value</b>																			
EOT	STX	03h	33h	ESC	D5	D4	D3	D2	D1	D0	ESC	T3	T2	T1	T0	ETX			
		Setting number (03)			basic price 6 digits							tare value 4 digit							
<b>Setting number 04: Basic Price, Text</b>																			
EOT	STX	30h	34h	ESC	D5	D4	D3	D2	D1	D0	ESC	A.....A				ETX			
		Setting number (04)			Basic price 6 digits							text 13 chars							
<b>Setting number 05: Basic Price, Tare value, Text</b>																			
EOT	STX	30h	35h	ESC	D5	D4	D3	D2	D1	D0	ESC	T3	T2	T1	T0	ESC	A.....A		ETX
		setting number (05)			Basic price 6 digits							tare value 4 digits					text 13 chars		
<b>Setting number 08: Status information Request</b>																			
EOT	STX	30h	38h	ETX															
		Setting number (08)																	
<b>Scale data reading</b>																			
EOT ENQ																			

### Scale Communications to a POS System

#### Setting number 02: Weight, Price, and Total Price

<b>STX</b>	<b>30h 32h</b>	<b>ESC</b>	<b>X</b>	<b>ESC</b>	<b>D4 D3 D2 D1 D0</b>	<b>ESC</b>	<b>D5 D4 D3 D2 D1 D0</b>	<b>ESC</b>	<b>D5 D4 D3 D2 D1 D0</b>	<b>ETX</b>
	setting no. (02)		 status 30H = lb 31H = lb. / 0,01 32H = lb. / 0,005 33H = kg		scale - weight 5 digits		Basic price 6 digits		Price to pay 6 digits	

#### Setting number 09: Status information

<b>STX</b>	<b>30h 39h</b>	<b>ESC</b>	<b>S1 S0</b>	<b>ETX</b>
	setting no. (09)		Status     Status: ASCII code 2 bytes	
			00 there is no error	
			01 general errors in the scale	
			02 parity error or more symbols that are permitted	
			10 invalid setting no.	
			11 invalid basic price	
			12 invalid tare value received	
			13 invalid text received	
			20 scale is still in motion (no standstill)	
			21 scale wasn't in motion since last operation	
			22 there is still no price calculation	
			30 weight is less than minimum weight	
			31 scale is less than 0	
			32 scale is overloaded	

## 6.1.10 Reserved

## 6.1.11 ICL

### 6.1.11.1 Data Format

9600 Baud (select 2400, 4800 or 9600)  
 7 data bits (select 7 or 8)  
 Even parity (select Even, None or Odd parity)  
 1 stop bit (select 1 or 2 stop bit)

### 6.1.11.2 Handshaking

For PC DB25 serial port connector: Jumper 4 to 5, and 6, 8, & 20 together.  
 For PC DB9 serial port connector: Jumper 4 to 6 and 7 to 8.

### 6.1.11.3 Command Descriptions

Command	COMMENTS																				
ENQ (05h)	Starts the communication sequence																				
ACK (06h)	Data Available																				
CAN (18h)	Repeat weighing																				
NAK (15h)	No acknowledgement																				
NUL (00h)	No data available																				
DC1 (11h)	Data Request																				
STX (02h)	Start of text																				
ID	Information byte, broken down into the following bits: <table border="1" style="margin-left: 40px;"> <thead> <tr> <th colspan="3">Bit</th> <th>Capacity</th> </tr> <tr> <th>2</th> <th>1</th> <th>0</th> <th></th> </tr> </thead> <tbody> <tr> <td>0</td> <td>0</td> <td>1</td> <td>15kg x 0.005kg</td> </tr> <tr> <td>0</td> <td>1</td> <td>0</td> <td>30lb x 0.01lb</td> </tr> <tr> <td>0</td> <td>1</td> <td>1</td> <td>6kg x 0.002kg</td> </tr> </tbody> </table> <p style="margin-left: 40px;"> <b>Bit 3</b> - Logic 1  <b>Bit 4</b> - Logic 1 means under/over range  <b>Bit 5</b> - Logic 1  <b>Bit 6</b> - Logic 1 indicates non-AVR capacities                 </p>	Bit			Capacity	2	1	0		0	0	1	15kg x 0.005kg	0	1	0	30lb x 0.01lb	0	1	1	6kg x 0.002kg
Bit			Capacity																		
2	1	0																			
0	0	1	15kg x 0.005kg																		
0	1	0	30lb x 0.01lb																		
0	1	1	6kg x 0.002kg																		
Weight	5 bytes with MSD first. If the scale registers underweight or overweight a data string with data of zero (00) will be transmitted with bit 4 (X) of the ID byte set to 1. In cases where MSD or LSD are not required a 'NUL' character will be transmitted in the unused position.																				
BCC	Block Check Character calculated as the even column parity (Longitudinal Redundancy Check) of all characters except the STX and ETX.																				
ETX (03h)	End of text																				
CR (0dh)	Data received and compared correctly																				



#### 6.1.11.4 Command Flow

ECR	Scale	COMMENTS
ENQ (05h)		
	ACK (06h)	Data Available. Errors could be: CAN - repeat weighing NAK - no acknowledgement NUL - no data available
DC1 (11h)		Data Request Errors could be: NAK – no acknowledgement
	STX ID W5W4W3W2W1 BCC ETX	Transmitted Data
STX ID W5W4W3W2W1 BCC ETX		Confirm Data Errors could be: ACK – Data not confirmed NAK – receive error or scale error detected.
	CR (0dh)	Data confirmed, CAN response to ENQ is activated until current transaction is cleared.

**Note:** The POS can request and receive additional weight data from the scale before returning the verification weight but the verification weight must equal the last weight sent by the scale.

**Note:** Spaces depicted in the description above are only used for ease of reading. No space characters are used unless the BCC result yields the space character.



METTLER TOLEDO  
1900 Polaris Parkway  
Columbus, Ohio 43420-2020

P/N: 72191204

METTLER TOLEDO® is a Trademark of Mettler-Toledo, LLC  
©2012 Mettler-Toledo, LLC